



Lubrication Accessories:

No lubrication accessories:

Not recommended. Manual lubrication required.

Lube Holders:

Provides basic lubrication on the bearing raceway.

1 polymer lubricator per side of rail

Wheel Cover:

Provides increased lubrication compared to the lube holders. Also provides a semi-enclosed cover for the wheels that helps keep debris and other contamination away from rollers. Provides 4 polymer lubricators per side of rail.

Wheel Cover and Lube Holder:

Maximum lubrication and increased life of the polymer lubricators. Provides 5 polymer lubricators per side of rail.

Additional lubrication may be required for specific operating environments.

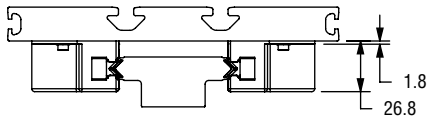
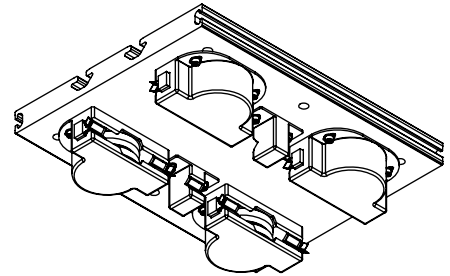

Lube Holder

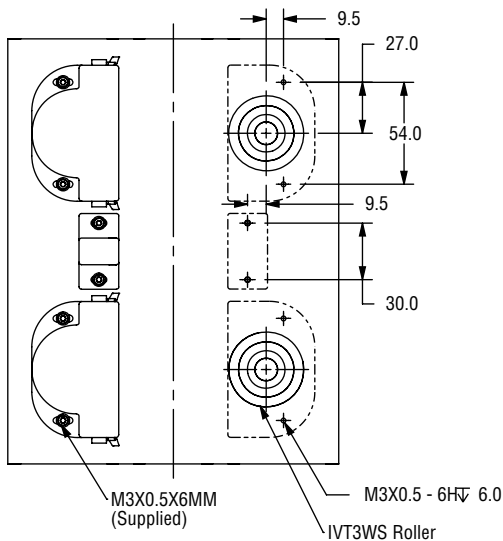
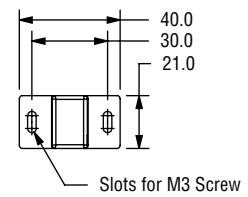
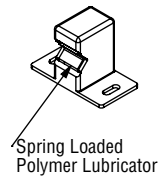

Wheel Cover

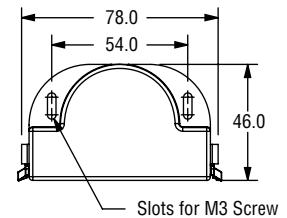
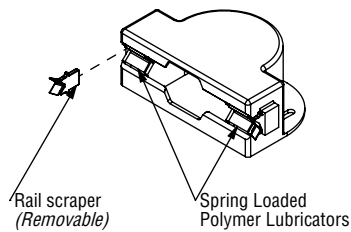

NOTE: Lubrication options are provided by PBC Linear, however it is the responsibility of the user to determine and ensure the system is properly lubricated.

Ordering & technical support call 1-888-777-1466
www.pbclinear.com

PBC
LINEAR
 A PACIFIC BEARING CO.



Roller Kits:

IVT carriages with hex-stud adjustment have rollers on one side that are fastened onto the carriage by concentric hexagon studs with M12 thread. Rollers on the opposite side are secured onto the carriage by fastening hexagon nuts and eccentric hexagon studs with M10 thread.

Concentric Stud

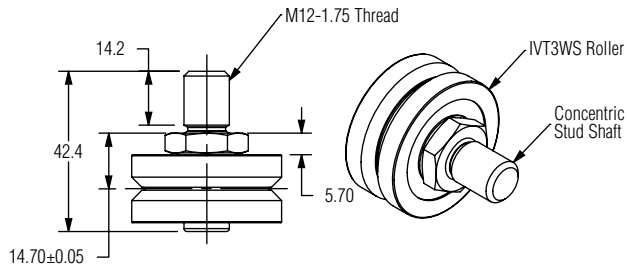

Eccentric Stud

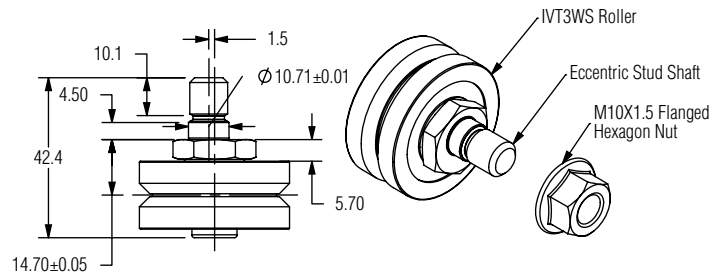

Wheel Cover Replacement Kit

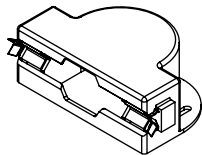

- Includes:
- (1) Plastic Wheel Cover
 - (2) Polymer Lubricators
 - (2) IVT Scraper
 - (2) M3 Screws & Washers

Ordering Information:

IVT3A-TWS	IVT3WS Roller with Concentric Stud Shaft
IVT3A-VWS	IVT3WS Roller with Eccentric Stud Shaft
IVT3WCA-KIT	Wheel Cover Replacement Kit
IVT3LHA-KIT	Lube Holder Replacement Kit
IVT3SCRIP	Replacement IVT Scraper (Qty: 1)

Lube Holder Replacement Kit

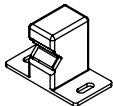

- Includes:
- (1) Plastic Lube Holder
 - (1) Polymer Lubricator
 - (2) M3 Screws & Washers

Torque Values:

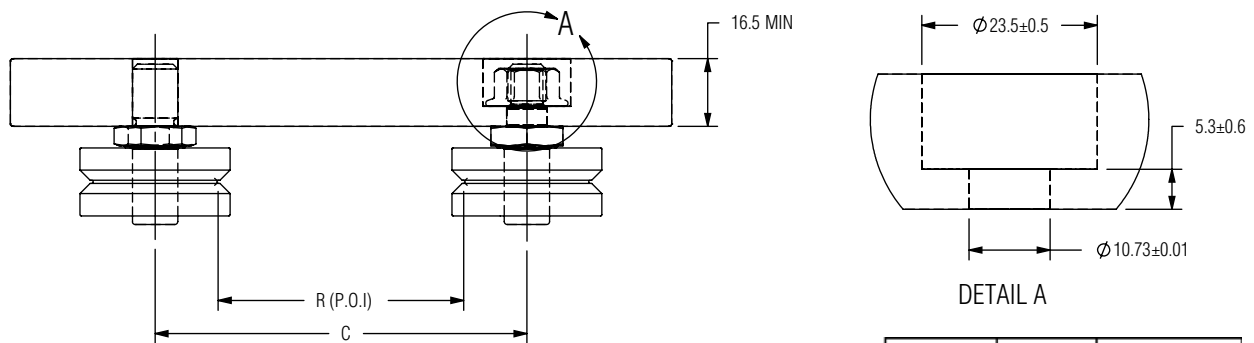

Reference relevant IVT rail page for R dimension.
C is calculated as follows: $C = R + 33.43$

	Stud Thread	Hexagon Flat	Tightening Torque (N-m)
IVT3A-TWS	M12X1.75	19mm	44
IVT3A-VWS	M10X1.5	19mm	36

1 N-m = 8.8507 in-lb

Ordering & technical support call 1-888-777-1466
www.pbclinear.com

PBC
LINEAR
A PACIFIC BEARING CO.