

MT Series

MTC Belt Driven Units - Linearantrieb Baureihe MTC

Belt driven guided unit using a flat design. Extruded aluminium anodized 6060 alloy, tempred stainless steel protection band. Carriage with Sealed system to protect against pollution.

Linearantrieb mit flachem Profil und Kugelumlauführung. Profil aus eloxiertem Aluminium 6060. Schutzblech aus gehärtetem Edelstahl. Dichtsystem für den Schlittenschutz gegen Staub.

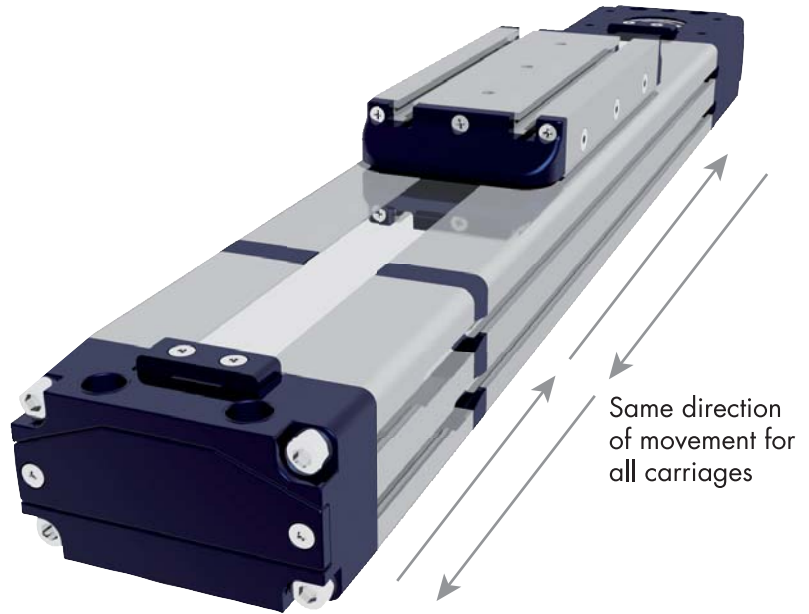

Same direction of movement for all carriages

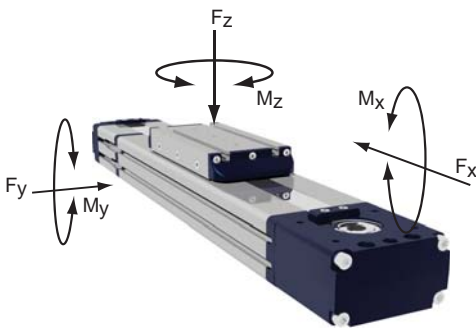

**Max values for dynamic conditions. Please refer to the following formula when combined loads are applied.

*Für die Ermittlung der maximalen dynamischen Tragzahlen bei kombinierten Kraftangriffspunkten, nutzen Sie bitte die nebenstehende Berechnungsformel.

$$\frac{F_{y_A}}{F_y} + \frac{F_{z_A}}{F_z} + \frac{M_{x_A}}{M_x} + \frac{M_{y_A}}{M_y} + \frac{M_{z_A}}{M_z} \leq 1$$

The A letters show the calculated value.

TECHNICAL DATA - TECHNISCHE DATEN

| | | | |
|---------------------------------------------------------------------------|-------|-----------------|------|
| Size - Baugröße | mm | 42x75 | |
| Number of runner blocks - Führungswagen | | 2 | 1 |
| Max. speed - Max. Geschwindigkeit | m/s | 3 | |
| Max. stroke length - Max. Hub | mm | 3000* | |
| Min. stroke length - Min. Hub | mm | 100 | |
| Pulley drive ratio - Hub pro Umdrehung | mm | 130 | |
| Number of teeth of pulley - Zähne der Riemenscheibe | | 26 | |
| Belt profile AT 5, width 12 mm - AT5-Profil Riemen 12mm Breite | | | |
| Max rpm - Max. Drehzahl der Antriebswelle | g/min | 2000 | |
| Base weight - Gewicht bei 0mm Hub | Kg | 2.7 | 2.5 |
| Add for 100 mm of stroke - Gewicht bei 100mm Hub | Kg | 0.5 | 0.5 |
| Max. load* - Max. Belastung | Fx | N | 615 |
| | Fy | N | 1275 |
| | Fz | N | 1275 |
| Moments* - Max. Belastungsmoment* | Mx | Nm | 18 |
| | My | Nm | 110 |
| | Mz | Nm | 110 |
| Inertia moment Aluminum profile - Flächenträgheitsmoment | Ix | cm ⁴ | 28 |
| | Iy | cm ⁴ | 37 |
| Repeatability - Wiederholgenauigkeit | mm | ± 0,05 | |
| Max. radial load on input shaft - Max. axiale Lasten an der Antriebswelle | N | 250 | |
| No load torque - Leerlaufmoment | Nm | 1 | 1,2 |

GENERAL DESCRIPTION / UBERSICHT

1. Body is an extruded, aluminum anodized housing - ease of mounting & cleaning
2. Steel reinforced belt to carry heavy loads
3. Ball guided rail system
4. Carriage is anodized aluminum with t-slots
5. Belt tensioning adjustment system
6. Motor Mount assembly available in two different shaft versions
7. T-slot for mounting actuator
8. T-slot for mounting limit switches
9. Sealed against pollution

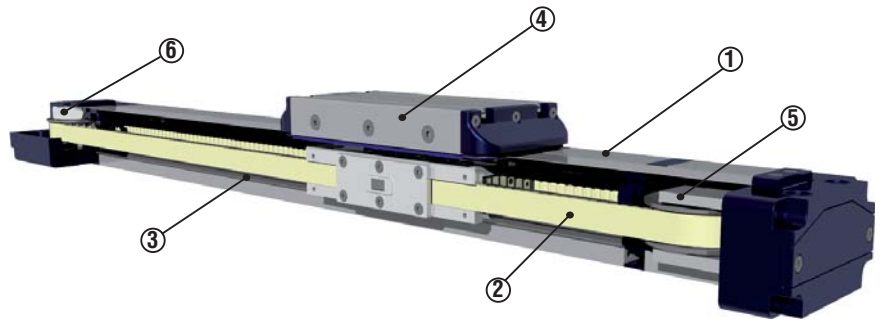

1. Selbsttragenden Profil aus eloxierter 6060 Aluminiumlegierung
2. Stahlverstärkten Polyurethan-Riemern mit AT Zahnprofil
3. Kugelumlauführung
4. Schlitten mit T-Nuten für die Befestigung und de Seitenschutz
5. Integriertes Zahnriemenstraffsystem
6. Antriebswelle verfügbar in 2 Versionen
7. Nuten für die Befestigung der Einheit.
8. Nuten für die Befestigung des Sensors
9. Dichtsystem für den Schlittenschutz gegen Staub

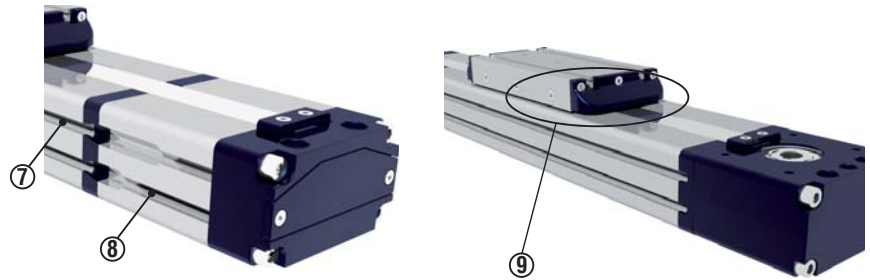

DIMENSIONAL INFORMATION / ABMESSUNGEN

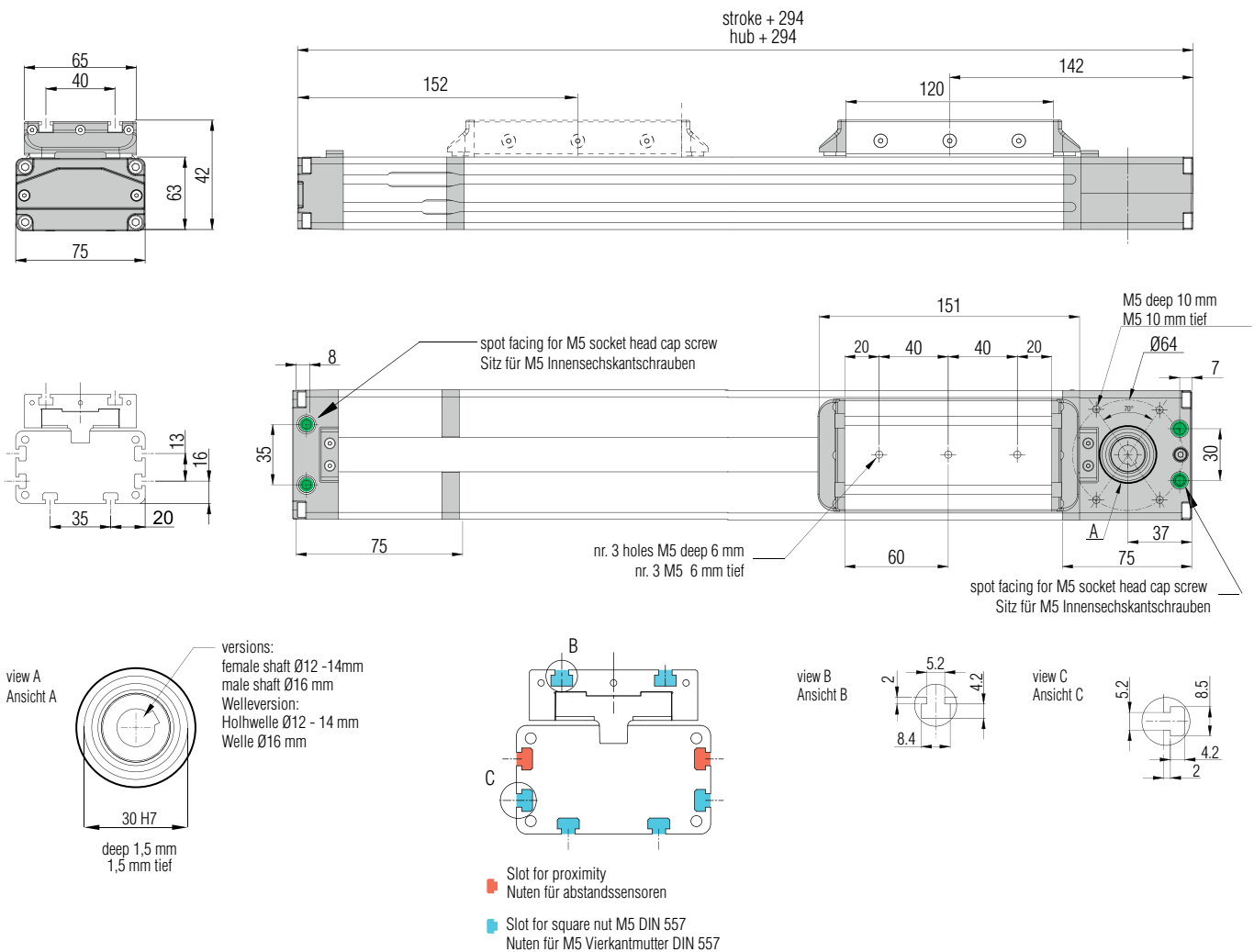

Telefon: +49 (0) 211 2503 422 • www.pbclinear.de

PBC
Lineartechnik GmbH™

The data and specifications in this publication have been carefully compiled and are believed to be accurate and correct. However, it is the responsibility of the user to determine and ensure the suitability of PBC Lineartechnik GmbH™ products for a specific application. PBC Lineartechnik GmbH™ only obligation will be to repair or replace without charge, any defective components if returned promptly. No liability is assumed beyond such replacement. Specifications are subject to change without notice.